

LINN LP12 TURNTABLE

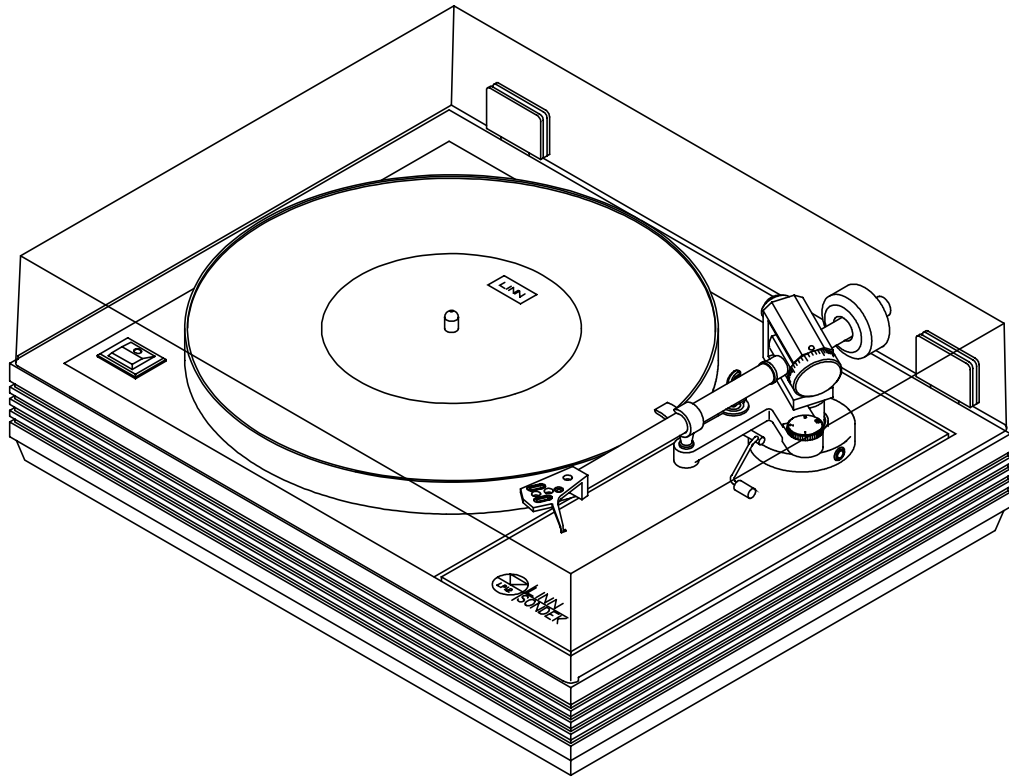

SET UP MANUAL

IN THE BEGINNING ...

This is where it all began back in 1973 - the Sondek LP12, which revolutionised people's perception of what produces 'good' hi-fi. At Linn we have demonstrated that turntables are the most important component in a record playing hi-fi system. Twenty five years after its introduction, the LP12 is still the reference turntable.

Since 1973, Linn has invested a great deal of time and effort upgrading the LP12; improvements which have had far reaching effects on the whole system. Today, the LP12 sounds significantly better than at any time in its history, and has an ever expanding customer base. Looking after 'yesterday's' customer has always been a priority at Linn, ensuring that almost all the upgrades are retrofittable, thus making it possible to upgrade any LP12 to current specification and performance.

This section is designed to assist you to carry out any requested upgrades to the LP12, to help you identify and correct minor irregularities, to familiarise you with recommended tools and provide useful information on LP12 specifications. We hope this section will help you provide better service to all your existing and future LP12 customers.

INDEX

Contents	Page
LP12 Introduction	2
LP12 Set-up	4
Required Tools	5
Set-up Jig	6
Preparation	7
Assembly	10
Suspension Adjustments	14
Arm cable fitting	17
Motor adjustment	21
Final Installation	23
Tips	24
Common Turntable Set-up Faults	25
LP12 Fault Finding	26
Lingo Fault Finding	32
LP12 Guidelines for Upgrade and Repair	
Lingo	33
Suspension Grommets	36
Motor Thrust Bearing	37
Bearing Housing "CIRKUS"	38
Armboard	41
Suspension Springs	41
Sub-chassis (glued)	42
Plinth	43
Valhalla Power Supply	44
Nirvana Kit	45
Valhalla Repair Kit	46
Valhalla Update Kit	47
Motor Adjustments	48
Linn Speedchecker	50
Kinky Arm Alignment Tool	51
T-Bar Bolt Straightener	52
45-rpm Adaptor	53
LP12 History and Upgrade Path	54
LP12 Specifications	57

LP12 SET-UP

INTRODUCTION

Estimated Time
for Completion of
task ~ 60 minutes

Important - read this before you begin

It is extremely important that you read this entire section before attempting to set up a Linn Sondek LP12 Turntable. Failure to do so may well result in substandard performance, and could result in permanent damage to the turntable.

We realise that the policy of most hi-fi dealers is, "If all else fails, read the instructions". The set up procedure used on the Linn Sondek, while not terribly difficult, is significantly different from that used on other turntables. It is virtually impossible to set the table up correctly without following the steps in this section.

These instructions refer specifically to the set up of the Linn Sondek LP12 fitted with a Linn Tonearm and cartridge.

Tightening Procedure

Since we are dealing with a transducer that has to recover information considerably smaller than a millionth of an inch from a phonograph record, it is important that all fasteners (screws, nuts, and bolts) in the turntable be very tight. Whenever the instructions call for you to tighten a fastener, we do mean tight - probably tighter than you would have imagined.

However, there is no advantage to tightening past the point where materials will deform, or where you damage the materials or destroy their structure. A good rule of thumb is simply to bring the nut or screw up to where it seems tight and then turn it about 1/8 turn more (in the case of armboard screws, which are put into wood, 1/16 turn will do).

Tools Needed For Set-Up

5.5mm or 7/32 Hollow Shaft Nut Driver

8mm or 5/16 Hollow Shaft Nut Driver

No. 1 Pozidrive Screwdriver

No. 2 Pozidrive Screwdriver

All cross slot screws on the LP12 are Pozidrive. While a Phillips screwdriver will work, the correct Pozidrive screwdriver is preferred.

Medium Size (about 5 mm wide) Flat Blade Screwdriver

Medium Size Needle Nose Pliers

12mm or Adjustable Wrench

5mm or 3/16 Wrench

1.33mm Allen Key

2mm Allen Key

3mm Allen Key

4mm Allen Key

Required allen keys, except for the 3mm, are supplied with Linn tonearms.

Turntable Set-Up Jig or Substitute

It is desirable to raise the turntable to about eye level so that you can reach and see the underside of the turntable. The set-up jig on a standard-height work bench is best.

The surface that the set-up jig or turntable rests upon must be absolutely steady and level for proper suspension adjustment. If the surface is unsteady or subject to rocking motion, the energy put into the suspension during the adjustment process can induce movement in the support surface as well as the suspension. Proper adjustment of the turntable suspension will be difficult, if not impossible under these conditions.

LP12 SET-UP JIG

We recommend that you always use a set-up jig when setting up an LP12. This will facilitate ease of adjustment, prevent damage to your turntable and ensure proper suspension adjustment.

1. Before using the jig make sure that the mounting plates have been covered with a protective strip. Fit protection to underside of clamp and place the jig on a stable surface.
2. Fit plinth carefully to set-up jig and lock in place.
3. Adjust jig feet until plinth is level. Check with a spirit level, both front to back and side to side.

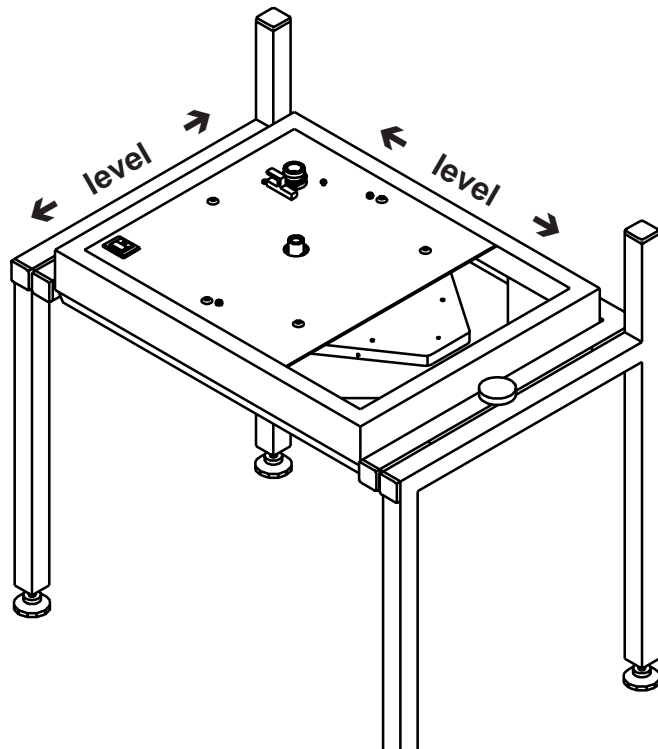

PREPARATION

The next steps cover unpacking the turntable and checking to see that none of the fasteners (screws, nuts or bolts) have become loose due to vibration in transit.

Caution



Make sure that the turntable is unplugged from the A/C outlet before removing the bottom cover. High Voltages (400 Volts!!!) are present on the Valhalla circuit board. Failure to observe this precaution can result in serious electrical shock.

Please note that, on turntables equipped with the Valhalla circuit board, the board is live at all times. The Valhalla switch does not turn the A/C power on and off; it simply sends a control pulse to the board which results in the motor being turned on or off.

1. Unpack the Turntable

Packed below the dustcover you will find:

- An armboard
- Two dustcover hinges
- Two baseboard screws
- Three armboard screws
- One inner platter/spindle assembly
- Two phials of main bearing oil

Underneath the turntable you will find:

- The outer platter, felt mat, and belt

2. Place Turntable in Set-up Jig

After placing the turntable in the set-up jig, lock the turntable into place. Use a spirit level to ensure that the turntable plinth (base) is level. This is done by adjusting the feet of the set-up jig.

Please note that if you are using a Linn set-up jig, you may lay the jig on its back at various times during set-up to provide easier access to the underside of the turntable (steps 3 to 6 for example).

However, when this is done you should first remove the inner platter and cap the main bearing well with the red plastic cover provided to avoid spillage from the bearing housing if it has been charged with oil.

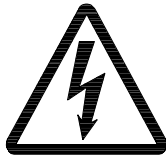

3. Remove Baseboard

Before proceeding with this step, stop and check to make sure the turntable is unplugged! To remove the baseboard, unscrew and remove the four feet on the bottom of the turntable.

If you are working on a previously set-up table, you will also have to remove the two baseboard screws that are located in the centre of both the front and rear edges of the baseboard.

NOTE: If the turntable is to be repacked in its original carton, the two baseboard screws must be removed. If left in, they will scratch the rim of the platter which is packed directly under the turntable.

4. Remove ground and P-Clip Nuts

Use the 8mm nut driver to remove the nut holding the turntable earth jumper wire to the front chassis bolt, and the nuts holding the nylon P-clip, washer, and green A/C ground wire (if fitted) to the rear chassis bolt. (See Turntable Exploded View).

5. Tighten Wiring Strap Nuts

Check to see that the nuts holding the wiring strap, on which the circuit board is mounted, are tight. These nuts are located directly under the ones just removed. The chassis bolts pass through the wood mounting blocks of the plinth. These wooden blocks may expand and contract due to temperature and humidity extremes during transit and this can result in the nuts working loose.

Observe the top surface of the stainless steel top plate as you tighten these nuts. Do not overtighten these nuts such that the stainless steel top plate becomes depressed or deformed beneath the heads of the chassis bolts.

6. Tighten Sub-chassis Ground Screw

Tighten the allen head screw which attaches the chassis earth jumper wire to the right rear edge of the sub-chassis.

With older turntables that do not have this screw, proceed to the next step or if welded type, drill the side of sub-chassis and relocate earth wire.

7. Tighten Top Plate Screws

By looking down at the stainless steel top plate from above, locate the two small pozidrive screws that help to attach the top plate to the plinth. They can be found next to the chassis bolts located at the centre front and centre rear of the top plate. Ensure that these two screws are tight.

8. Check the Position of the Motor

Check the position of the motor mounting bolts in the elongated slots in the top plate. These are the two bolts on the extreme right and left of the motor.

On current turntables, (50 Hz pulley, 21mm diameter) the motor mounting bolts should be in the middle of the adjustment range. While this can be accomplished by carefully aligning each of the two motor mounting screws in the middle of the slot provided, it is easier and far more accurate to simply have one motor mounting bolt at the extreme outside of its slot, and the other motor mounting bolt at the extreme inside of its slot.

In countries with 60 Hz mains supplies, older turntables may have a smaller (17 mm) diameter pulley. On these LP12s the motor should be in the outermost position. This is accomplished by having both motor mount bolts at the extreme outside of their slots.

Please note:

All new turntables are factory fitted with the larger, 50Hz pulley, and thus should have one motor mounting bolt at the extreme outside of its slot and the other motor mounting bolt at the extreme inside of its slot.

Both Lingo and Valhalla power Supplies use the 50Hz motor/pulley.

Motors with 60 Hz pulleys as supplied in the appropriate BASIK power supply kit and are not compatible with the Lingo or Valhalla power supply.

Original Valhallas supplied to countries with 60 Hz mains were supplied 60 Hz Valhalla boards.

9. Check Motor Mounting Nuts

After you have checked the position of the motor mounting bolts, check that the nuts on the motor mounting bolts are tight, using the 5.5 mm nut driver.

Do not over-tighten these nuts or you will simply crush the motor mounting domes!

10. Check Bearing Housing Bolts

Check that the bolts which mount the bearing housing and oil well to the sub-chassis are tight. These are accessible from the top, through the hole in the centre of the stainless steel top plate, by shifting the sub-chassis from one side to another.

Current "Cirkus" LP12 turntables use 4 mm socket head (Allen key) bolts. Older units may use 2 mm, 2.35 mm 2.5mm or 3mm socket head bolts, Phillips screws, or slotted screws.

POWER SUPPLIES

Since 1991 (serial number 87600) the LP12 has been supplied as a mechanical assembly only, without power supply factory fitted.

Three different power supply options are available: Lingo, Valhalla and Basik. Valhalla and Basik. If you are setting up a new turntable see separate instructions for fitting the power supply.

ASSEMBLY

Some instructions in this section, concerning certain tools and fasteners, are specific to Linn tonearms. Procedures may vary slightly if other tonearms are used.

11. Mount the Tonearm Base on the Armboard

In the case of the Linn arms, the arm base is fastened from the bottom of the arm board with three 4mm socket head bolts with lock washers. Read section on Kinky arm alignment tool before proceeding.

To Locate Properly

With arms using other mountings, ensure that the mounting screws, bolts, or nuts are properly tightened observing the tightening procedure. With arms using a single large mounting nut, reaching the proper tightness does require the use of a spanner, not just your fingers!

12. Mount the Arm Rest - Ittok LVII/LVIII

When fitting the Linn Ittok LV11 arm, mount the armrest on the armboard in the hole provided. This will need to be drilled out.

Position the LVII armrest such that its knurled height locking screw will be to the outside when the armboard is mounted on the turntable.

Tighten the mounting nut on the underside of the armrest very tightly with a 12 mm or adjustable wrench. Tighten the knurled height locking screw only finger tight for now. After you make the final arm height adjustments you will likely need to re-adjust the height of the armrest, before finally locking it in position.

13. Mount Tonearm collar

Place the tonearm in the mounting collar on the armboard. Tighten the screws fingertight only at this stage.

14. Mount the Arm Board

Use only the screw supplied for mounting the armboard. Do not substitute any other screws for the supplied screws!

Mount the armboard on the turntable sub-chassis. leave the screws slightly loose at this point.

15. Mount the Cartridge

Mount the cartridge on the tonearm with stainless steel cartridge nuts and bolts, as supplied with all Linn tonearms and cartridges. Do not completely tighten down the mounting bolts at this time. The cartridge must be mounted loosely enough to allow you to shift its position with your fingers for alignment before finally locking it in position. See Seperate procedure for complete details.

16. Charge Turntable Bearing with Oil

Discharge the entire charge of oil provided into the bearing well - i.e. two small 1 ml phials of Linn oil. Wrap a tissue around the bearing housing to absorb any overflow.

17. Fit Inner

Carefully insert the inner platter/spindle assembly into the bearing well and gently lower into position; ensure that you support it while lowering. Do not drop the inner into the bearing well, as irreparable damage may result!

When the spindle reaches the bottom of the well, a small amount of oil should flow from the top of the well. No overflow indicates an insufficient amount of oil. In this case remove the inner platter from the well and add more oil (say 5 drops at a time) until a small overflow results when the inner platter is again carefully placed into the well. Once this oil reservoir is full raise the inner platter to remove and discard tissue.

18. Install the Belt

Upon inspecting the belt you may find that one surface is slightly smoother than the other. The smoother side should be considered the INSIDE of the belt. (If the turntable has been used, the inside of the belt can be identified by a thin, polished silver pulley track running along near the centre of the belt - clean before refitting) Fit the belt to the motor pulley and outside surface of the inner platter.

19. Mount the tonearm

Align using "KINKY" alignment tool to determine correct location for the armboard, see separate procedure for "Kinky" Alignment tool for details. Take care not to strip the holes in the armboard. If you do, replace the armboard; refer to tightening procedure.

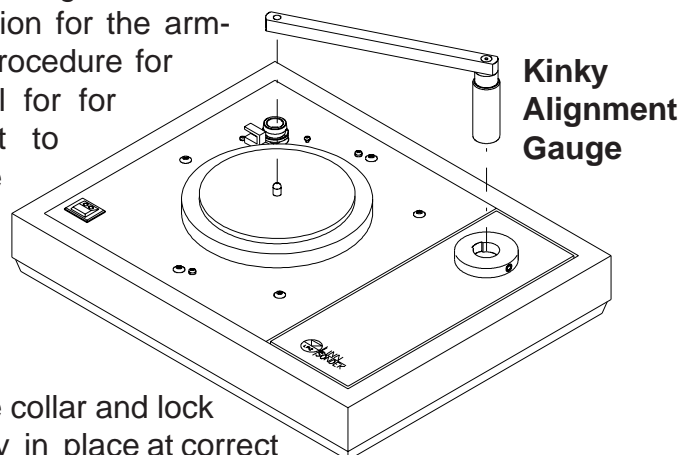

Fit the tonearm into the collar and lock the tonearm temporarily in place at correct height by lightly tightening the height locking screw in the tonearm base (See procedure on Mounting the Cartridge for details).

20. Tonearm Counterweight

Gently fit the counterweight on the tonearm, being careful not to subject the arm bearings to undue force.

On dynamically balanced tonearms such as the Linn Ekos/Ittok, balance the weight of the cartridge by adjusting the counterweight position; then apply the required tracking force with the tracking weight dial.

On statically balanced tonearms such as the Linn Akito/Basik, balance the weight of the cartridge with the counterweight position; then adjust the tracking dial (without moving the counterweight) to put the zero weight position in line with the mark on the arm, under the "0" line position. Rotate the counterweight such that it moves towards the bearing housing (towards you) until the line indicates the desired tracking weight on the counterweight dial.

21. Install Outer Platter and Mat

Carefully fit the outer platter onto the inner platter. Place the felt mat on top of the platter surface.

22. Align the Cartridge

Place a flat record on the platter.

Align the cartridge position in the tonearm headshell using the Linn alignment protractor. See Cartridge procedure for details.

After aligning the cartridge, remove the tonearm from the turntable and tighten down the cartridge with a 2 mm allen key while holding the nuts with a 5 mm wrench.

Linn cartridges must be mounted very tightly in the headshell. If the cartridge body is not strong enough to allow it to be mounted tightly, it cannot perform at its best. All Linn cartridges, except the K5, are metal bodies and can be tightened properly.

To avoid damaging critical arm bearings never, under any circumstances, tighten or loosen cartridge mounting hardware with the tonearm mounted on the turntable!

Force applied at the headshell can, by way of the lever action of the arm tube, be amplified and transmitted to the delicate precision bearings of the arm. This damages the bearings. The main pillar of the arm must always be allowed to move freely (i.e. not be attached to the mass of the turntable) when a cartridge is tightened in the headshell.

23. Adjust Tonearm Height (vertical tracking angle)

Replace the tonearm and adjust the height so that the arm tube is parallel to the surface of the record on which the stylus rests. Lock the tonearm in position with the 4 mm allen key supplied.

The tonearm should be very tightly locked. Again, ensure the proper restraint. Do not use any additional bar on the allen key to gain added torque. Doing so will make it possible to tighten the arm height lock bolt to the point where the arm pillar (and hence the arm bearings) is deformed.

If mounting a Linn Ittok LVIII arm, at this time you should readjust the height of the arm rest and tighten the knurled height locking screw as tightly as possible.

SUSPENSION ADJUSTMENTS

Level Set-up Jig

Use a spirit level to check once again that the turntable plinth is level. Adjust the set-up jig feet if necessary.

25. Level Suspension

Level the suspension by turning the nuts under the three spring/grommet assemblies up or down. The rear of the armboard should be levelled by adjusting the nut under the rear spring assembly. The front of the armboard should be levelled by adjusting the nut under the front spring assembly and the suspended system as a whole should be levelled left to right by adjusting the nut under the left spring assembly.

When the suspension is levelled correctly, the top of the armboard should be flush with the top edge of the plinth, and the platter should be level relative to all edges of the plinth. Do not align to the inside edge of the top plate (the one parallel to the armboard) as this is part of the suspension and it is not unusual for this to have a slight dip.

26. Adjust Springs

It is necessary that the suspension is allowed to move freely in all directions, and that it be adjusted so that it bounces easily, straight up and down. This can be tested by gently tapping the platter in the area where the inner

and outer platters meet, on a straight line between the centre spindle and the tonearm bearing housing. The whole suspended system should bounce straight up and down with no sideways or erratic motions.

If it is necessary to adjust the suspension, first check that the grommets are properly seated. Then unplug the signal lead from arm. Begin with the spring/grommet assembly on the left side of the turntable. Rotate the entire spring/grommet assembly a little at a time (1/16 to 1/8 turn) until the action of the suspension is as straight as possible. Next, move to the front spring/grommet assembly and adjust it in a similar manner. Lastly, move to the rear spring/grommet assembly and adjust it in the same manner.

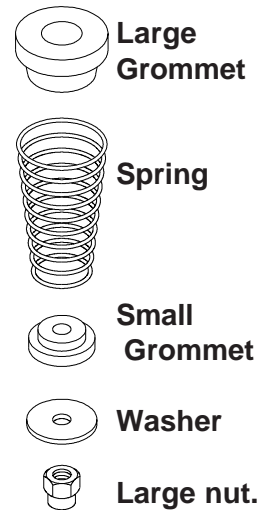

Each time you rotate a spring/grommet assembly, ensure that the entire assembly rotates during adjustment so that you do not introduce a twist in the spring. As you finish adjusting each spring, push up slightly and then release the washer on which the spring/grommet assembly rests. This will release any twist which may have been introduced into the spring.

Note that as you rotate a spring, the level of the suspension may change. If this is the case, re-adjust the level as necessary before moving to the next spring.

Once you have adjusted all three springs, if the suspension is not satisfactory repeat the adjustments, starting again at the left, moving to the front and then to the rear. You may occasionally have to go around the table two or three times to fully adjust the suspension.

When you are finished, the suspension should be able to move freely in any direction, and move roughly straight up and down when tapped as described earlier.

If you should have problems, make sure that you have not moved the suspended assembly to a position in which any top grommet touches the chassis bolt that passes through it. Also, check that the armboard is not touching the stainless top plate or the plinth.

27. Check Suspension

When you are finished with step 26 there is one last test. Remove the outer platter (to enable the suspension to relax) and then replace it onto the inner platter. If the suspension still works properly you are finished with the operation.

If the suspension no longer moves straight up and down this may be an indication that one or more of the springs was not properly seated on the top rubber grommet. The springs should be readjusted as outlined in step 25.

Don't panic. While the suspension adjustment may seem a bit complicated, it is actually quite simple. With a bit of practice you will find that it is easier to adjust the suspension than it is to read about it.

ARM CABLE FITTING

28. Straighten Cable

Before moving the arm cable, straighten any bends or kinks it has from having been packed. If necessary, heating the cable slightly with a hair dryer is permissible.

After straightening the cable, put a 90 degree twist in it right behind the plug, as shown .

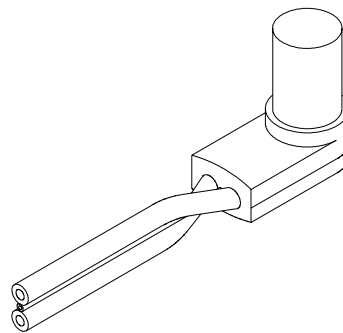

29. Pre-form P-Clip

Pre-form the P-clip by squeezing it tightly together momentarily with a pair of pliers, as shown in the illustration.



30. Re-attach A/C Earth Wire (Valhalla / Basik)

Replace the green A/C earth wire, and associated nut, on the rear chassis bolt and tighten securely.

31. Put P-clip on the Arm Cable

Place the P-clip on the arm cable about 170 mm from the plug. (The accuracy of this distance is not critical.)

To achieve the tightest clamping of the arm cable, it should be passed through the P-clip such that the cable's wide dimension will run vertically, as shown in the illustration.

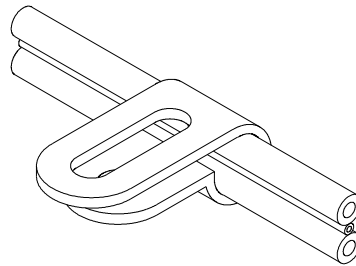

Slip the washer, P-clip, and associated nut onto the rear chassis bolt with the loop of the P-clip towards the rear of the turntable. Do not tighten the nut at this time.

32. Replace Chassis Earth Wire

Replace the chassis earth jumper wire, and associated nut, on the front chassis bolt and tighten securely.

33. Attach Arm Earth

Cut eyelet on the armlead's ground wire. Remove insulation approximately 5 mm and solder to eyelet of chassis ground wire where it is affixed to the sub-chassis by the allen head screw.

If you are setting up an older LP12 that does not have this allen screw attaching the chassis earth, it is recommended that you drill a small hole (3mm) on the side of the sub-chassis and relocate the earth wires to this point. Use stainless steel cartridge mounting nut and bolt.

34. Plug in Arm Cable

Plug the cable into the arm. Allow enough slack so that the cable is not pulling on the suspension, but not enough to allow the cable to dip and rest on the bottom panel or to push on the suspension.

The goal is to dress the arm cable such that it does not change the resting position of the suspension or degrade the straightness of its vertical motion when tapped. This is easily checked; Check the "bounce" before and after fitting the arm cable to the arm - there should be no difference to the "bounce". If there is re-check the length and tension of the arm cable between the p-clip and the arm and adjust as necessary.

Do not re-adjust the suspension with the arm cable fitted to the tonearm.

35. Tighten P-Clip

Tighten the nut that holds the P-clip until it is just short of causing the P-clip's ratchet surfaces to engage. Keep the P-clip parallel to the wiring strap.

Slip a screwdriver through the elongated hole at the top of the P-clip and, using the wiring strap washer as a pivot and the screwdriver as a lever, pull up around the cable.

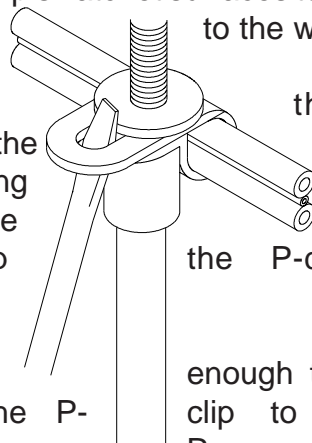

through the top of the P-clip strap washer as a pivot and the screwdriver as a lever, pull up around the cable.

Tighten the nut enough to engage the ratchet teeth of the P-clip to prevent it from sliding back open. Remove the screwdriver and hold the P-clip to prevent it from rotating while you finish tightening the nut. Tighten the nut until it just begins to bite into the nylon of the P-clip.

enough to engage the ratchet teeth of the P-clip to prevent it from sliding back open. Remove the screwdriver and hold the P-clip to prevent it from rotating while you finish tightening the nut. Tighten the nut until it just begins to bite into the nylon of the P-clip.

It is important that the P-clip runs parallel to the wiring strap and is not rotated to one side. When you are done with this operation it should not be possible to pull the arm cable through or to move the P-clip, regardless of how hard you tug.

36. Feed Cable through Plinth

Bend the cable to route it through the cutout supplied in the rear of the plinth (the cable will make a sharp S-bend).

37. Re-Check Cable Tension

Unplug the arm cable from the arm pillar. The position of the armboard should not change whether or not the cable is plugged into the arm, as this would indicate that the arm cable is pushing or pulling on the suspension.

If the armboard is being pulled slightly, it is usually possible to correct this without completely redressing the cable. Grasp the cable next to the P-clip firmly between thumb and forefinger and pull down its entire length towards the plug. This will usually stretch it enough to correct the problem.

If the armboard is being pushed slightly, slacken the P-clip nut and turn the P-clip VERY SLIGHTLY. Then retighten the nut that holds the P-clip in place. (Note that the P-clip should be positioned with its length parallel to the wiring strap, so the amount of allowable rotation is very small). If this will not correct the problem, redress the cable by repeating steps 35 to 37.

38. Lock Arm Cable

When the cable is dressed such that it touches nothing between P-clip and arm pillar, does not affect the position of the armboard when plugged in, and does not affect the suspension operation, lock the plug in position with the set screw in the arm pillar using the 1.5mm (or 1.3 mm) Allen key.

Do not overtighten the set screw as this will destroy the tonearm cable.

39. Replace Bottom Panel

New Turntables:

There are two options of base boards:

- 1 Solid base
- 2: Trampolin : Suspended base

See separate instructions for fitting.

Replace the bottom panel. Screw in all four feet and the screws in the front centre and rear centre of the bottom panel. Check when replacing the bottom panel to ensure that the arm cable and mains cable exit through the slots provided, and that the arm cable does not rest on the baseboard.

MOTOR ADJUSTMENT

How to Adjust Speed

Caution

Make any adjustments in small increments. Take care to **always loosen one screw** before tightening the other to avoid bending the motor casing which will degrade the performance of the turntable (see page 50).

Once the correct belt position is achieved, ensure that both tilt screws are turned down such that both just firmly touch the top of the motor casing.

Further tightening will simply bend the case of the motor, degrading the sound of the turntable and rendering proper speed adjustment difficult if not impossible.

39. Adjust Speed (also see Speed Checker)

Remove the record and place the Linn Speedchecker disc onto the felt mat. Place the bracket on the Speedchecker strobe unit into the left hinge plate. Turn the turntable on and let it run for a few minutes before checking the speed.

Turn the Speedchecker strobe on and note the movement of the lines on the outer ring. If the lines move to the right (clockwise), the speed is too fast. If the lines move to the left (anti-clockwise), the speed is too slow.

The speed of the turntable may be increased by loosening the motor tilt screw closest to the rear of the turntable and tightening the tilt screw nearest the spindle. Conversely, the speed of the turntable may be decreased by loosening the tilt screw nearest the spindle, and tightening the tilt screw nearest the rear of the turntable.

These adjustments should be made in small increments (about 1/8 turn of each screw). The resolution of the Speedchecker is quite high and small screw adjustments will make large changes in the drift noticed on the Speedchecker. A drift of one line per second indicates a speed error of only 0.3%.

With the use of the Linn Speedchecker, it is quite easy to adjust the speed to within 0.01%.

Finally check with the outer platter fitted upside down that belt does not foul belt guide and runs on crown of pulley.

40. Motor Bearing Adjustments (large end cap)

**NB: Only applies to LP12's below serial number
87047 (Valhalla)
87206 (Lingo)**

The adjustment of the turntable should now be complete. It is normal for the turntable motor to make a very soft ticking or scraping sound if you listen for it quite close to the turntable. This will normally quieten after 24 hrs. However, if the motor makes a noticeable loud ticking or scraping noise, the motor bearing requires adjustment (this is not a motor fault).

Remove end cap from the motor and check ball bearing

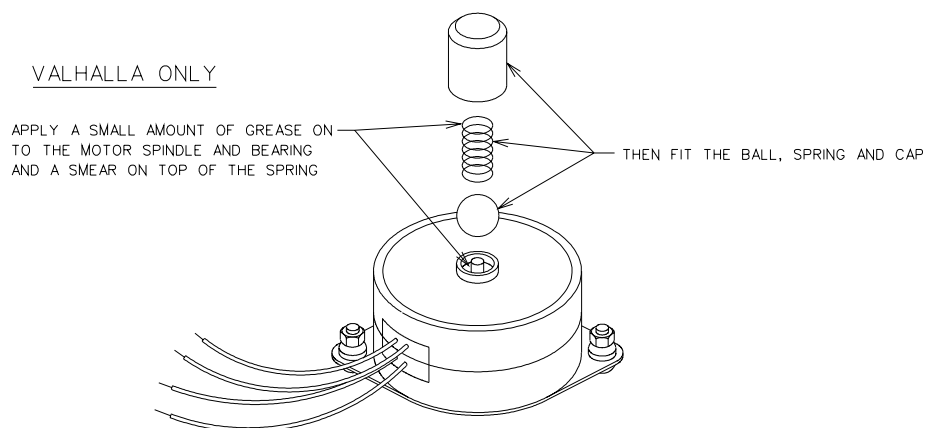

is properly greased. Use Linn black grease only. Refit the assembly to the bottom of the motor. After replacing the cap, push down on the motor pulley from above. The pulley should go down, then spring back to its original position when released. If you dislodge the cap when pressing down on the pulley, the spring assembly has not been properly seated in the cap, and/or there is grease on the mating surfaces of the cap and flange.

Once everything is in order, replace the bottom panel. Plug the turntable into the mains, turn it on, and check to see that the motor noise is now satisfactory.

FINAL INSTALLATION

41. Place the Turntable on a Proper Surface

A turntable's musical performance can be optimised by selecting the proper surface or support on which to place it.

Folk wisdom once was that a turntable should be placed on a very massive support. The misconception is that massive objects, because of their inertia, will best isolate a turntable from airborne vibration from the loudspeakers.

However, although these heavy objects may move by very small amounts, they move at very low frequencies which will bypass the suspension of a turntable. The turntable then responds to external, low frequency noise such as vibration from traffic or central heating furnaces.

A lighter support tends to move at much higher frequencies that can be managed by the turntable suspension, and so do not effect the performance of the turntable.

Standard isolation bases with additional suspensions should also be avoided. The additional suspension can interact in an uncontrolled way with the suspension of the turntable creating a very unstable position. For the same reason any shaky or unstable surfaces should be avoided. The ideal turntable support would be rigid and light-weight. Suitable tables include some light coffee tables.

TRAMPOLIN

A wall mounted shelf is often a good location for a turntable. Fit the TRAMPOLIN, the Linn base board with suspended feet. The shelf itself should tightly bolted to the brackets that support it.

Likewise, If you want to use a turntable on a heavy equipment cabinet loaded with records and amplifiers, fit the TRAMPOLIN base board to isolate the turntable. You must, however, make sure that the equipment cabinet itself is stable and does not rock back and forth. Have the cabinet seated firmly on the floor (not carpet), or braced against, or fastened to, the wall.

42. Check Tonearm

Check the Tonearm "0" balance, tracking force and anti-skate (bias) adjustments

43. Play Music

You are now ready to connect the turntable to your system and play music!

Carry out the "Tune Dem" to establish correct setup before and after carrying out any modifications or upgrades to ensure that you are getting the best from the LP12.

Tips:

1. When fitting Linn Tone-arms split the arm cable between the phono leads and the LP12 so that left, right channels and earth are no longer joined together along the length of the cable. They will pull apart quite easily without damaging the cable.
2. Always ensure that the belt is clean. Use a household polish, sprayed on to a clean cloth, gently pull the belt through the wet part of the cloth, then dry on a dry part of the cloth. Repeat until belt stops dirtying the cloth.
3. Mains plugs must be clean, tight, and into proper wall sockets. Using multiblocks generally ruins the sound.

COMMON TURNTABLE SET UP FAULTS THAT AFFECT SOUND QUALITY

Turntable set up faults often account for complaints about inferior sound quality. To avoid these faults, remember to check out the turntable for the following:

- Loose or stripped fasteners;
- Over-tightened or broken parts including electronic components;
- Dirty or poor electrical connections including earths;
- Motor mounting plate bent due to poor adjustment;
- Motor pulley eccentric following mishandling or knock;
- Top-plate rattling at motor corner;
- Motor pulley and inner platter dirty;
- Outer platter to inner platter faces dirty;
- Belt dirty or perished;
- Inner or outer platter out of balance following a drop;
- Wrong mat;
- No oil/insufficient oil;
- Arm cable dressed wrong - loosely clamped or touching baseboard or plinth;
- Suspension shorted or badly adjusted;
- Suspension washer dished;
- Transit screws improperly removed;
- Poor quality mains plug (MK or moulded leads recommended);
- Unauthorised modifications;
- Wrong speed;
- Loose feet;
- Turntable not on a level surface;
- Mains plug position (usually best next to pre-amplifier);
- Use of a comparator or excess connections.

LP12 FAULT FINDING

These are a few of the most common LP12 faults that we have experienced.

Symptom	Fault	Solution
Turntable doesn't reach correct speed	Dirty/Worn belt	Clean or replace belt
	Voltage on Valhalla set too low	Check volts at motor wires connecting block: Red phase - 85 V +/-1 V Blue phase - 75 If incorrect trim RV1 until 85 V +/-1V across red. Use non-magnet trim tool and allow Valhalla to warm up by connecting to mains for a few minutes before adjusting.
	Poor/No connection at motor wires switch	Check wiring to motor for poor connection. Common fault is wire breaking at connecting block due to terminal screw over-tightened, or mis-handling of wires. Check volts output to motor.
	Top-plate bent	Remove motor from top-plate and try straightening motor mounting plate if possible. If this is not possible, replace motor. (replacement not under warranty)

Symptom	Fault	Solution
Turntable Won't Reach Correct Speed (Cont'd)	Black gunge in Motor Bearing	See separate document Motor Flush Instructions.
	Motor thrust Spring too Tight	Replace with new springs (Valhalla only)
	Tight Bearing Housing	<p>Has bearing been run dry? If so, replace (page 38). Has bearing been run with wrong oil? (Black oil should not be used with white liner bearings as it may cause liner to swell. Use a light mineral machine oil).</p> <p>Has inner been fitted to the bearing with the plastic protection sheath? If so, clean out the bearing (this protection was used until early 1990 to protect the spindle - now they are simply oiled).</p> <p>Check the spindle for 'polish' marks which indicate that the spindle has been used dry, or that the bearing liners are too tight. If polish marks are present, replace inner platter</p>

Symptom	Fault	Solution
Turntable doesn't reach correct speed (cont'd)	Tight bearing housing (cont'd)	<p>Check oil level- it must be full with inner fitted (approx. 50 drops or two 0.9 cc oil phials). Use only Linn supplied oil to avoid damage to the bearing liner and to protect the warranty.</p> <p>NB. Lower the inner GENTLY to avoid damage to the bearing Spin platter by hand, it should spin freely and come to a gradual stop.</p> <p>Note: Prior to 1987 bearing housings were not vented. Turntables to this spec. will require a few minutes to allow the spindle to drop Probably long enough to have a cup of tea!</p>
Turntable doesn't revolve	Motor dead a. LED dead	<p>Check fuse on mains plug. Check mains fuse on PCB. If blown, check R1. Unless bridge rectifier is rated at 1000V (KY500 or 1KAB100E) fit Valhalla Repair Kit (see page 46).</p>

Symptom	Fault	Solution
Turntable won't revolve (cont'd)	b. LED on	Check volts at motor wires connecting block: Red phase - 85 V +/-1 V Blue phase - 75 V If incorrect trim RV1 until 85 V +/-1V across red. Use non-magnet trim tool and allow Valhalla to warm up by connecting to mains for a few minutes before adjusting.
Turntable runs in reverse	Red/Blue wires reversed at PCB	Check and re-wire.
Noisy motor		See Motor Section, page 48.
Outer platter oscillates	Platter warped or off balance	Has platter been dropped? If so, replace. If not, clean matching surface to inner platter on both platters. Try it with another platter. If confirmed, return to Linn Service Dept. for checking.
Outer platter fouling top plate	Suspension set too Low	Check armboard is not too thick. Specification is 10.3 mm +/- 0.3 mm. If thicker than this it will cause the whole suspension to be set too low.
Outer Platter not level	Bearing housing not square on sub-chassis	Remove bearing housing and check matching surface on sub-chassis for excess glue, or mis-aligned strengthening strap. If ok, clean and re-assemble.

Symptom	Fault	Solution
Outer platter not level (cont'd)	Sub-chassis twisted	Check locating holes on sub-chassis for signs of distortion. If distorted, replace subchassis.

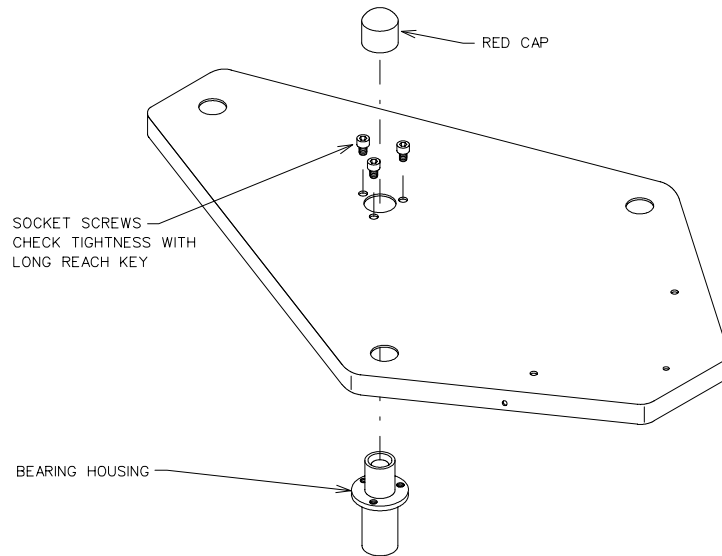

Plinth screws won't tighten	Stripped screw holes	<p>Either:</p> <p>a. Repair using cocktail sticks and pva glue to fill screw hole. Leave to dry before using; or</p> <p>b. Use longer screw eg. 6 x 3/4" self-tapper, instead of 6 x 1/2". If repair is not effective then replace plinth.</p>
-----------------------------	----------------------	--

Symptom	Fault	Solution
Turntable rocks on surface	Feet not properly fitted	Refit feet or if damaged fit new feet.
	Plinth warped	Specification for plinth warp is 1.5 mm weighted (full weight of LP12, including lid, platters, arm, without feet fitted). Measure using feeler gauge under high corner. If warped, it is not possible to repair. Fit Trampolin or Replace plinth (under warranty if less than 2 years old).
	Turntable mounting surface not level	Level or change mounting surface
Armboard does not tighten	Screws over-tightened	Replace armboard. (not under warranty)
	Counter-sinking too large	Replace armboard.
Lid does not remain in open position	Springs in hinges too weak	Change hinges to new spec, ie. hinge springs are gold in colour.

LINGO FAULT FINDING

Symptom	Fault	Solution
Product dead	Fuse blown	Check fuse in mains plug and in Lingo. Replace if blown. Internal fuse: use correct value, antisurge. 200 ma for 220 - 240 V 300 ma for 100 - 120 V
	Voltage barrel not fitted.	Fit barrel - be sure to set correct voltage.
	Faulty mains lead	Re-check all connections. Try another mains lead.
	Loose power connector	Remove case of Lingo and check Molex connector, from transformer to board, is fitted correctly.
	Faulty power interconnect lead	Try a known working lead
Hum after fitting LP12 no longer tied to mains		Contact Linn for special earthed Lingo lead. CONN 401/E This only applies to amplifiers with floating earth, which rely on the turntable to earth the system (not Linn amps).
Failure to reach 33 or 45 rpm	Faulty motor	See page 48
	Faulty Lingo	Try with another Lingo. Return faulty Lingo to Linn.
LED on LP12 stays bright (stall detector working)	Obstruction to platters/motor	Check and clear.
	Faulty motor - bearings tight	See page 48.

LP12 GUIDELINES FOR UPGRADE AND REPAIR

LINGO

Date Introduced: 1990

The Linn LINGO is a high precision, direct coupled, power supply designed to sit alongside the LP12 turntable. The Lingo upgrade moves the LP12's performance into a new league, further distancing it from the competition.

At the heart of the Lingo are two very low noise crystal oscillators derived from the Linn Numerik digital studio recording system - one for 33.33 rpm and one for 45 rpm. The switch on the turntable selects the appropriate oscillator, the output of which is fed into a synchronous counter to produce a 50 Hz or 67.5 Hz square wave for 33 rpm and 45 rpm respectively.

As the LP12 motor runs at its quietest when driven with a clean sinusoidal waveform, a precision filter is employed in the Lingo to remove harmonics from the square wave leaving only a pure wave form.

The most uniform torque is delivered from the motor when both phases are driven at ninety degrees with respect to one another. This is achieved by a ninety degree phase-shift network after the filter. The two resulting sinusoids drive two high voltage, Class A amplifiers, the outputs of which drive the two motor windings.

The Lingo uses 'stall detection' circuitry to feed the motor with a higher voltage for increased start-up torque. When the platter reaches the selected speed, this load-sensing circuitry reduces the power output. From then on the motor just maintains the platter's own inertia to keep it going silently.

A toroidal transformer on the PCB, and a mains filter, give a very high degree of electrical isolation from the mains voltage supply.

Fuse/Mains Voltage Selection

Open the fuse-holder door with a small flat-blade screwdriver. Select the correct fuse (200mA for 220/240V, 300mA for 100/120V). Fit it into the fuse-holder and install in the inlet filter.

CAUTION: Remove the voltage selector barrel BEFORE rotating it!

Set the correct voltage on the voltage selector in the mains input module, and snap the door shut. Tick off the appropriate box next to the right fuse on the Lingo bottom-label and DISCARD the two incorrect fuses.

Lingo/LP12 Conversion Procedure

Estimated Time for Completion of task ~ 30 minutes

WARNING: Disconnect the Mains Supply from the Turntable

1. Remove the base from the LP12, remove all the wires from the Valhalla board terminal blocks and remove the old switch assembly. Take out the Valhalla board by squeezing the stand-off clips with a pair of long-nose pliers.
2. Install the interface board, snapping it onto the same inserts that held the Valhalla.
3. Connect the interconnect lead by pushing on the multi-way connector. Fix this into the turntable exactly as you would the mains lead.
4. Push the new switch through the top-plate, and connect the flexible PCB to the connector, as with the Valhalla.
5. Connect the motor to the terminal block.

NB: See printed pcb for wiring instructions.

6. Remove the motor end-cap, spring etc, including thrust-pad if fitted unless end cap is small type and fixed in position with glue.
7. Set arm-lead, check set-up etc., and replace base-board.
8. Check speed and adjust as required - see page 50.

THE CORRECT COLOUR OF WIRE IS MARKED ON THE BOARD

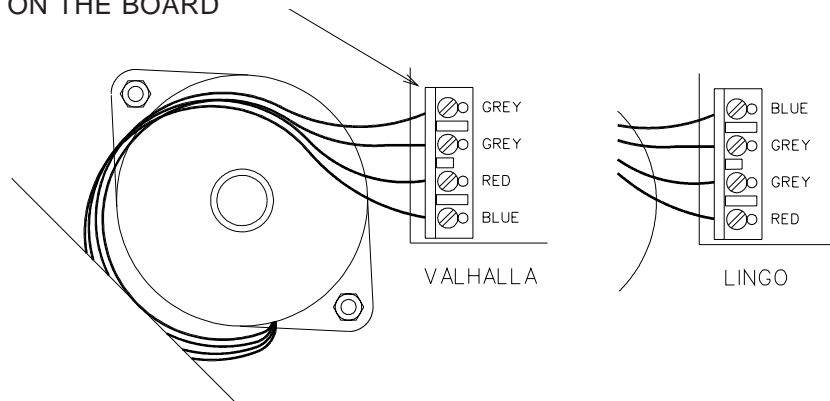

WITH THE LINTO, FIT THE MOLEY CONNECTOR ON THE MAINS CABLE TO THE TERMINAL BLOCK.

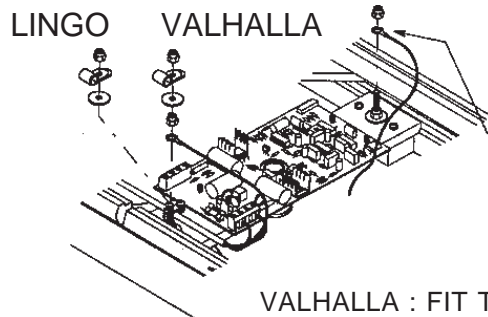
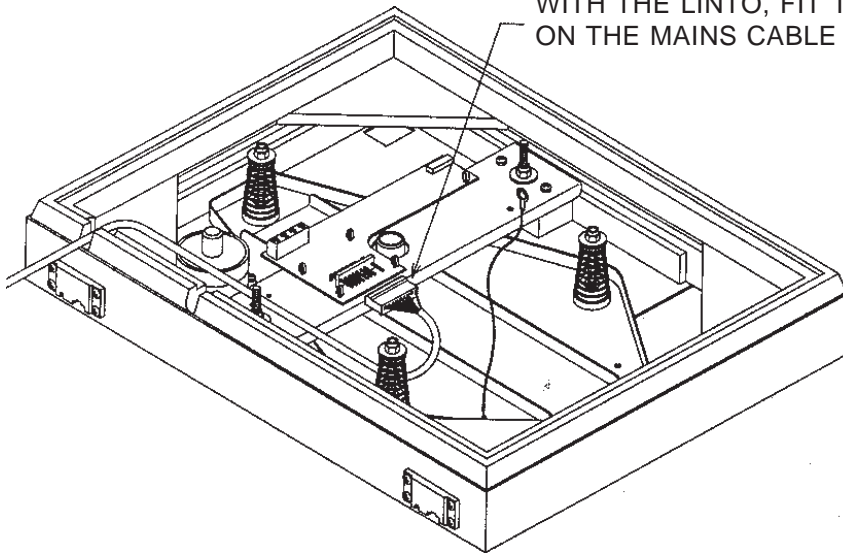

FIT THE SUB-CHASSIS EARTH TAG OVER THIS BOLT AND LOCK IT WITH A NUT.

VALHALLA : FIT THE MAINS EARTH WIRE OVER THIS BOLT WITH A P-CLAMP FOR THE NEW ARM CABLE.

LINGO:FIT THE P-CLIP ONLY (UNLESS USING CONN 401/E SCREENED LEAD)

SUSPENSION GROMMETS

Introduced - 1989

This upgrade changes the composition of the grommets to a harder, denser rubber. This new material specification enhances the performance of the suspension and therefore, of course, improves the sound quality of the turntable.

When updating older LP12s remember to change all the suspension grommets and related parts to those listed below. These parts are also supplied in the LP12 Spares Kit (part no. SK-LP12) or in the CIRKUS bearing upgrade.

Components

- 3 x small grommets
- 3 x large grommets
- 3 x suspension springs
- 3 x washers
- 3 x M5 nuts

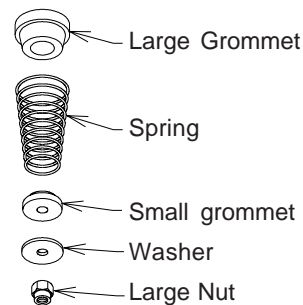

Service tips:

1. Ensure large grommet is cleanly located in sub-chassis hole.
2. Ensure small grommet is not caught in the thread of the chassis bolt. After fitting, push the small grommet and washer up, halfway toward the sub-chassis, and then release gently.

For more detailed information on set-up, please see the LP12 Set-up, Suspension Adjustments, page 14.

MOTOR THRUST BEARING (Valhalla)

In 1989, at around serial number 79,700 a modification designed to reduce motor noise and improve sound quality was fitted. It was fitted as standard to all Valhalla turntables.

In 1991 a Factory fitted new small thrust cap was introduced. This replaces the previous motor thrust bearing arrangement and is suitable for all LP12's. As this is glued in place it requires no maintenance, and cannot be re-fitted to existing motors.

To update older turntables:	Estimated Time for Completion of task ~ 15 minutes
------------------------------------	--

Either fit a new motor or upgrade as detailed below.

1. Unplug turntable from mains.
2. Place turntable on a jig and remove base-board;
3. Remove motor end-cap;
4. Discard end-cap, spring, thrust-dome and pad.
5. Position the new spring in the new end-cap and push it firmly home, until it clicks into place.
6. Cover the ball-bearing with the molybdenum disulphide ('black') grease and place on top of spring.
7. Re-position cap on end of motor.

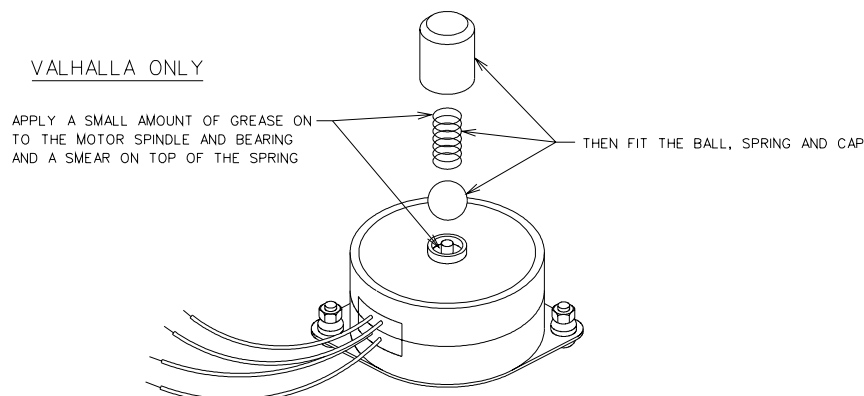

BEARING HOUSING Circus Upgrade

Introduced April 1993

Serial Number 90582

The CIRKUS upgrade to the LP12 focuses on bearing performance and the connection of the bearing housing to the sub-chassis. The improved bearing and stronger sub-chassis arrangement provides the turntable with greater stability and ensures the bearing sits perfectly true to the chassis of the turntable. This in turn minimises the risk of turntable platter movement with respect to the sub-chassis and arm. Even the slightest movement will introduce audible degradation to the reproduced signal.

Together the changes to the bearing and the sub-chassis make an enormous difference to the overall performance of the turntable. The specific changes are as follows :

1. The thickness of the bearing housing mounting flange has been substantially increased and undercuts eliminated to make it many times more rigid. This also allows the use of larger mounting bolts.
2. Increased distance between top and bottom liners in the bearing housing to make it as stable as possible eliminating even the smallest amount of rocking
3. An increase in the height of the bearing housing from the top of its inner liner to increase oil capacity, ensuring proper lubrication of the top bearing at all times
4. Double thickness sub-chassis to improve rigidity, reducing flexing and improving control of the relationship between key components

The complete kit of parts, which includes a new inner platter and spindle, is supplied to fit this upgrade. As always with Linn product improvements, all new LP12 turntables since April 93 have incorporated this upgrade as standard.

On earlier LP12s you may find different colour bearing housings and liners, representing the various changes over the years. The following list, starting with the original bearing housing, will help you identify the upgrade path taken.

BEARING HOUSING continued

Bearing Housing Colour	Bearing Liner Colour
1. Silver	Black
2. Silver	White
3. Gold	White*
4. Black	White (1984)
5. Black	Black (1987)
	Serial No.(Approx.) -70,000
6. Black	Black: CIRKUS kit
	Serial number 90582.

* Use this bearing housing with a light mineral machine oil. Black Oil can cause it to seize.

IMPORTANT NOTE

When replacing a bearing housing and updating to the latest specification, remember that the upgrade will involve changing two parts - the bearing housing and the inner platter/spindle.

Failure to replace both components will result, except in the case of a new, unused LP12 in a rapid deterioration of performance. All required parts are supplied in the CIRKUS Kit (page 38).

Oil Change

If you suspect that the bearing housing oil is contaminated, or that incorrect oil has been used, change the oil as follows:

1. Clean out the old oil using one of the following methods:
 - a. use plastic syringe to suck out oil.
 - b. use paper tissues or cotton buds to mop up oil from bearing housing.
 - c. drain oil by turning turntable upside down over old cloth/tissue.

Use cotton buds to clean out residue.

Remove any foreign matter in bearing housing, if found.

Do not use any solvent as you may damage the liner material.

2. Replenish with new oil. Use approx. 50 drops Linn Oil.

***Note:** Use Linn gold coloured oil for gold coloured bearing housings. (Velocite 6 or equivalent).

CHANGING A BEARING HOUSING AND INNER PLATTER:

Estimated Time for
Completion of task ~
60 minutes

If sub-chassis is old (spot welded), we recommend that you upgrade it for the new (glued) sub-chassis at the same time. Both form part of the CIRKUS Upgrade Kit and come ready assembled.

1. Fit LP12 to Set-up jig.
2. Remove outer platter, belt and inner platter
3. Plug bearing housing using red bearing cap.
4. Check that mains is disconnected, and remove turntable base.
5. Remove flexible PCB switch connector from Valhalla (or Lingo).
6. Remove M5 nuts securing 'P' clip, earth wire (if fitted) and the metal wiring strap with the Valhalla/Lingo PCB.
7. Remove the motor connecting wires from terminal block.
8. Remove sub-chassis/bearing and using correct tool remove the three bearing housing screws.*
Note: Current screw size is M4.
If fitting the CIRKUS KIT fit the new sub-chassis and bearing to the LP12, then proceed to step 10
9. Fix the new bearing housing using the screws supplied with the bearing; tighten them as much as possible, avoiding distortion of the chassis, then fit to LP12.
10. Refit wiring strap, motor wires, arm cable, earth wire, flexible pcb switch connector and base board.
11. Fill new bearing housing with Linn Bearing Oil.
12. Gently lower new inner platter into bearing housing.
13. Fit belt and outer platter.

*If bearing screws are difficult to release, try again using a new Allen key. If Allen bolt heads are stripped it may be necessary to drill the screws out.

ARMBOARD

Introduced - 1987 Serial No. (approx.) - 79,160

The latest LP12 armboard is made up of an MDF core, laminated top and underside. This improvement better optimises the rigidity of the arm board.

Most LP12s are fitted with the EKOS armboard which accommodates Ekos and Akito tonearms. This armboard is also suitable for the Ittok arm by simply drilling out the hole for the separate arm rest.

This armboard must always be fitted with the screws supplied (MECH 012), ensuring a tight fit to the sub-chassis, without stripping the screw holes.

We can also supply armboards for Rega and SME tonearms, as well as blank armboards to allow use with other tonearms.

Service Tips

1. Screw armboard screws into armboard until finger tight.
2. Use "Kinky" arm alignment jig to set position of arm to sub-chassis. Tighten armboard screws, holding armboard flat on to sub-chassis to ensure proper fitting.

Note : See Section on 'KINKY' Arm Alignment Tool (page 51)

BLACK SUSPENSION SPRINGS

Introduced - 1981

The springs, being an integral part of the LP12 suspension, have undergone various improvements over the years.

1981 Manufacturing tolerances were tightened to produce higher quality component. Springs were ground top and bottom. Colour changed from zinc to black to identify change.

1986 Further tightening of manufacturing tolerances. Springs wound anti-clockwise to identify change.

1988 Tightened grinding tolerances to ensure top and bottom faces were parallel.

For details on LP12 Set-up using the latest specification springs, please see LP12 Set-up, 'Suspension Adjustments', page 14.

SUB-CHASSIS (glued)

Introduced - 1984

Serial No. (approx) - 54,100

Upgraded - 1993

Serial Number - 90582

The original LP12 sub-chassis was pressed from one piece of mild steel, and ribbed to improve rigidity. In the late 70's we discovered that a much better sound was possible by replacing the ribs with a strengthening bar, spot welded in place.

In 1984 we made the second major improvement to the sub-chassis. Fastening the strengthening bar to the body of the sub-chassis using epoxy glue, in place of spot welds, gave a superior bond between the two components. This improvement eliminates sub-chassis rattle and more tightly controls the behaviour of the suspension. The epoxy glue is heat cured in our own oven at over 100 degrees centigrade.

There is a hole punched on the side of the sub-chassis to facilitate attaching the earth from the turntable and tonearm. This means that you do not have to use on the armboard mounting screws to secure earth tag to sub-chassis.

1993 saw the Introduction of the CIRKUS kit- see page 38 for full details.

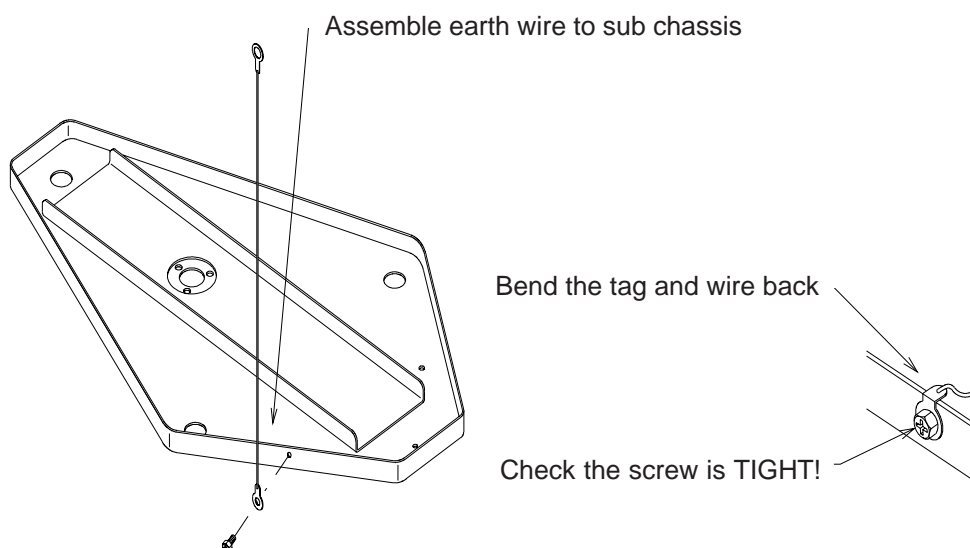

PLINTH

Introduced - 1984

Serial No. - 54,000

In 1984 the plinth was improved and strengthened to increase its inherent rigidity. This upgrade was achieved by increasing the size of the plinth corner blocks. As the corner blocks are such an integral part of the construction of the plinth it is not possible to modify older plinths.

March 1992 Serial number 88950, saw the addition of a "stud" welded to the top-plate. This improves the coupling to the plinth and secures the motor corner.

IMPORTANT: Do not over-tighten the nut on this stud. Tighten to between 50 and 60 cNm.

To Fit New Plinth:

Take the plinth and fit the top plate with 2 screws

Additional stud

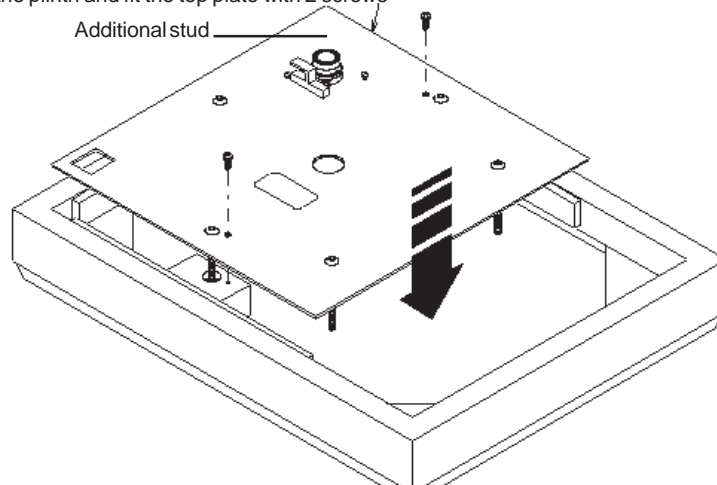

Fit the wiring strap with 2 washers and screws

Do not overtighten the nuts on the wiring strap!

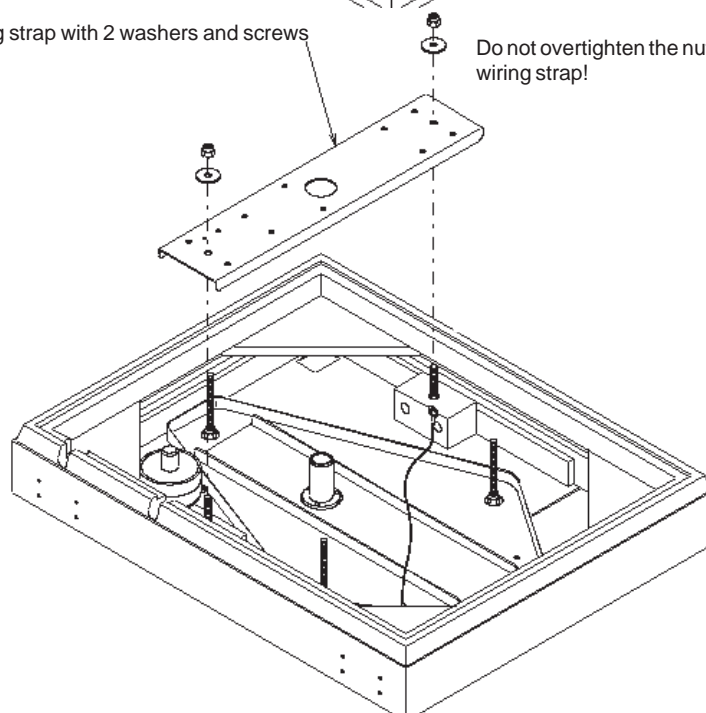

VALHALLA POWER SUPPLY

Introduced - 1982

Serial No. - 38,800

The Valhalla circuit board is designed to isolate the rotation of the turntable motor from variations in the mains supply. The circuit board operates by using a crystal oscillator, dividing it down to 50 Hz, filtering it to form a pure sinewave, then amplifying this signal to a level which drives the motor.

The switch provides a trigger to the electronics, making the motor start or stop. This involves power being on the circuit board constantly, while it is connected to the mains. The static power consumption is very low, but a slight warmth may be felt on the baseboard.

The circuitry will have the longest life expectancy when continuously connected to the mains. However, if desired, it may be disconnected at night, for example, without impairing reliability.

The Valhalla will drive almost all LP12 motors, with the possible exception of very early motors (coded MB10). It drives the motor with 85V A/C across the red phase. The blue phase is driven through a phase shift capacitor at approximately 75 V.

**For fitting the Valhalla see separate document:
"LP12, Circuitry Kit Fitting Instructions".**

NIRVANA KIT

Introduced - 1981 Serial No. (Approx.) - 32,800
 The Nirvana upgrade kit, introduced in 1981, was designed to improve the suspension and motor mounting of the LP12. The kit itself has been upgraded over the years, reflecting the improvements to the LP12 components.

The Nirvana kit was discontinued in Jun 1992, but most of the parts are still available separately or as part of the LP12 Spares Kit (SK-LP12)

List of parts :	Part Number:
Suspension springs (3 per kit)	2F-052/A
Large grommets (3)	2R-002/A
Small grommets (3)	2R-001/A
Large locknuts (3)	1F-102/A
Small locknuts (6)	1F-123/A
Chassis bolt (5)	2F-084/A
Bearing Mounting Screws M3	1F-060 *
Motor mounting screws (2)	1F-062/A
Motor mounting nuts (2)	MECH 007/A
Motor mounting domes (4)	MECH 061/A
Motor thrust bearings:**	
endcap (1)	MCP 087/2
spring (1)	MCP 087/2
ball bearing (1)	MECH 140*

/A = bagged quantities.

* These parts are no longer available : New CIRKUS bearing uses M4 screws (MECH 055), Motor thrust bearing has been replaced with a factory fitted glued end-cap.

Background history:

** In 1991 a Factory fitted new small thrust cap was introduced. This replaces the previous motor thrust bearing arrangement and is suitable for both Valhalla and Lingo LP12's. As this is glued in place it requires no maintenance.

NB The original Valhalla thrust bearing used two teflon mouldings: one dome was fitted to the spring and the other to the end of the motor spindle. Both mouldings have been replaced with a 9 mm ball bearing which sits on the spring, locating on the end of motor spindle. This must always be lubricated using the black bearing grease available from Linn.

Initially, before this upgrade was established, a few thrustbearings were fitted with a smaller ball bearing and used the moulded pad fitted to the end of the spindle - this was superceded by the 9 mm ball bearing with no pad.

This old thrust bearing assembly is not required for the Lingo and must be removed when updating any LP12 from Valhalla to Lingo.

VALHALLA REPAIR KIT

Contents of Repair Kit:
(available from Linn on request)

- 1 x BR1
- 1 x VR1
- 1 x FUSE

Estimated Time of Completion for this task ~ 30 minutes
--

Resistor R1 has been replaced with a varistor and all old R1s should be changed to this new component. When a fuse AND R1 blows it is necessary to check the bridge rectifier. This should be rated at 1000 V. If not, replace with one that is BY500 or KB1000.

Fitting: REMEMER TO UNPLUG THE TURNTABLE FROM THE MAINS!

1. Use a temperature controlled 25 w soldering iron with a cleaned, tinned tip, and a de-soldering tool (a solder sucker is ideal).
2. After removing old BR1 and R1 clean the pcb if required, before inserting the new components. For cleaning purposes use a lighter fuel or IPA.

NB: Observe the polarity and make sure that you insert the bridgerectifier the correct way round. Getting this wrong will result in a fireworks display when you plug it in.

VALHALLA UPDATE KIT.

Parts:

- 2 x 63v Zener diode
- 1 x 12K Resistor

Tools:

- Electric Drill
- 1. mm & 1.5mm Twist drill
- Soldering iron, with fine bit and solder
- Needle file/scrapper.

Procedure:

1. Drill two 1mm holes through the board into the track from the gray and blue terminals. Drill two 1.5 mm holes between these points where the component legs are to be soldered together- these holes, **must not make contact with adjacent track.**
2. Remove the solder resist from the tracks around the 1mm hole.

3. Fit componets in place as shown, the zener diodes go back to back, ie. the stripes face each other, and solder the outer legs of the diode to the tracks , then twist and solder the inner legs to the resistor.

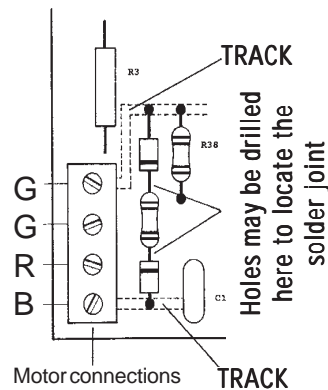

4. Trim the legs . The joints should be trimmed to about 2mm.
Double check that there are no shorts between the joints and the tracks.
5. Audition before returning to the customer.

MOTOR ADJUSTMENTS

Most turntable manufacturers 'soft mount' the motor on springs or rubber bands. Linn has chosen to 'hard mount' the motor to achieve a more rigid arrangement. This is done by bolting the motor to the stainless steel top-plate and the plinth base, using high tensile steel allen screws and stainless steel mounting domes and nuts.

This hard mount arrangement requires that the motor is attached securely enough to make the effective mass of the motor housing the complete plinth and top-plate. Most vibrations from the motor are transferred to the plinth and not to the belt, to the sub-chassis and record. As of May '91 all motors for LP12 Valhalla and Lingo are supplied with a new smaller motor end cap glued in place. For previous motors see the following section. Please note this new end cap is suitable for both Valhalla and Lingo turntables and requires no maintenance.

Valhalla:

Hard mounting the motor means that the vibration can sometimes be heard as an acoustic noise, direct from the turntable. It should never be loud enough to be intrusive - a good guide is that you should not hear it when you change a record.

If the motor with large cap does make a noticeable, loud ticking or scraping noise, the motor bearing requires adjustment:

1. Check if thrust bearing consists of large ball bearing, ie 9 mm instead of 7 mm ball bearing. If not, replace.
2. Ensure ball bearing and tip of spindle are well greased - use Linn black' grease.
3. If large end cap is fitted, check end of motor spindle for any rough spots; buff end of spindle with emery cloth to remove any rough spots.
4. Re-grease and re-fit thrust bearing assembly to end of motor.

LINGO:

The Lingo requires either the new small (glued) end cap or the removal of the large thrust bearing assembly.

Occasionally an old motor will be too noisy, or will not run correctly with the Lingo. Double check that the motor is at fault by connecting the Lingo to another LP12. If fault is confirmed contact Linn Service Dept. who will supply a new motor - usually under warranty.

Remember that there is a running-in period for new motors of up to 36 hours continuous running. You can accelerate the noisy run-in period by leaving a Lingo LP12 on at 45 rpm overnight for a few nights to quickly achieve quiet running in the new Lingo position.

LINN SPEEDCHECKER

Estimated Time
of Completion for
this task ~ 15
minutes

Components:

- 1 strobe disc/alignment protractor
- 1 strobe box
- 1 bracket for use with Linn hinge back plates

Power Supply:

The strobe box is powered by a 9 volt PP3 battery.

Instructions for Use:

Run the turntable for at least 5 minutes before setting the speed. This allows mechanical and electronic parameters to stabilise.

Put strobe disc on turntable. Slot strobe box/bracket into hinge bracket furthest away from arm so that LED points at disc. Select speed to be checked. Turn LED on by pressing rocker switch on the front panel. Look from above the strobe box and use the bracket end as a reference point. Speed is correct if lines appear stationary, clockwise movement means fast; anti-clockwise movement means slow - adjust as necessary.

Note: The strobe is easier to use out of direct light. Hand held use is possible with or without bracket. If speed accuracy is less than 0.3% (one line per second) , correction may be possible by turning belt around, or inside out.

Speed Adjustment:

Before adjusting speed, clean the drive belt. Increase speed by loosening tilt screw furthest from bearing housing and tightening other tilt screw by an equal amount. Decrease speed by loosening nearest and tightening furthest.

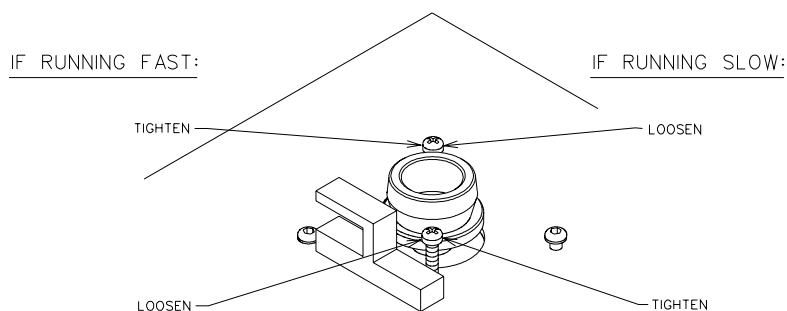

After adjustment, both screws should be in contact with motor top-plate. Note: These screws should be snug only! Further tightening will simply bend the case of the motor, degrading the sound of the turntable and rendering proper speed adjustment difficult, if not impossible.

Check that belt does not foul guide by inverting outer platter and running turntable.

"KINKY" ALIGNMENT TOOL Estimated Time of
Completion for this
task ~ 15 minutes

This tool has been designed to take the guess work out of positioning the armcollar with reference to the Turntable bearing. This is based on an stylus overhang of 18mm, arm bearing to turntable bearing distance is 211 mm.

Instructions for Use:

1. Ensure armboard is parallel in armboard cut out.
2. Remove arm and outer platter.
3. Fit Kinky as shown in drawing. If Kinky locates over turntable spindle proceed to step 7, otherwise armcollar will need to be adjusted.
4. Slacken the three screws holding armcollar to armboard.
5. Place Kinky in arm collar and slide other end over the inner spindle.
6. Tighten the height locking screw against the Kinky to lock it into position, making sure the leg of Kinky is flat on inner platter.
7. Tighten armcollar screws.
8. Remove Kinky and re-fit arm; check suspension is still correct.
9. Using cartridge alignment protractor, check alignment and adjust position of cartridge as required. See arms and cartridge section for fitting of cartridges to arms, and use of alignment protractor.

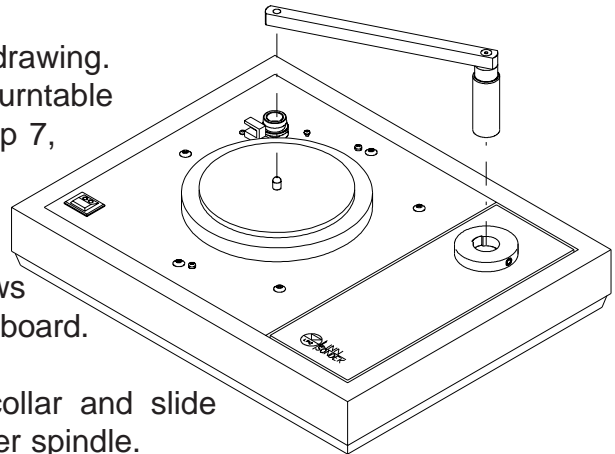

**T-BAR BOLT
CHECKER/STRAIGHTENER**

Estimated Time
of Completion for
this task ~ 30
minutes

The T-bar bolt checker makes all
turntable suspensions easy to set up.

Instructions for Use:

1. Put LP12 in jig, remove baseboard.
2. Adjust jig until plinth is level in both directions. Use a good spirit level. Do not use the lower part of this t-bar as a conventional level as the bubble is set to be at 90 degrees to the bolt.
3. Remove one set of grommets and springs.
4. Attempt to fit t-bar over first bolt; several conditions may exist:
 - a. t-bar will not fit over bolt. This indicates the bolt shaft is badly bent and must be replaced.
 - b. t-bar fits over bolt either snugly or with a small amount of slack.
 - i. move the t-bar gently from side to side to find the average position of the bubble.
 - ii. if it is not central, support the plinth whilst bending the bolt with the t-bar until it is central.
 - iii. revolve the t-bar by 90 degrees and repeat steps i. and ii. The bolt will now be parallel to the plinth. Re-fit spring, grommet and nut.
5. Repeat stage 3 and 4 for the other two bolts.
6. Set the suspension.

Note: Do not drop or mis-handle the t-bar. If you do break or bend it you may return it to us for repair/re-alignment.

Use the suspension setting tool to check that the suspension bolts are straight. The bubble must be central in the spirit level.

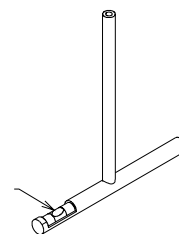

Turn the tool through 90 degrees and check in the other plane.

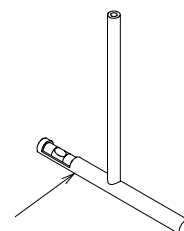

LP12 45 RPM ADAPTOR

A 45 rpm adaptor is available for the LP12 turntable and is supplied as standard with the Basik power supply. The adaptor consists of a slip-on ring which fits over the existing pulley, and a new belt. The old belt should be used with the adaptor, the new belt being intended for use at 33 rpm.

This adaptor is recommended for occasional use only. We would recommend that the LP12 be upgraded to the Lingo which as well as being an substantial sound upgrade, provides 45 and 33 r.p.m. speeds without the need to use a manual adaptor.

LP12 HISTORY AND UPGRADE PATH

Sound quality, as always, remains our top priority. The following changes were made primarily as sonic improvements. However, in many cases these changes have also had an advantageous effect on manufacturing techniques, assembly procedures and easier LP12 set-up. Each upgrade is explained in further detail in the following pages.

Upgrade	Year	Serial Number (approx.)
25 year Anniversary of LP12! Silver badge on back. Special piano laquer available (special order)	1997	95000
Cirkus LP12 Cirkus bearing and subchassis upgrade fitted as standard. See page 38 for details.	April 93	90582
Top Plate with Stud Fitted with additional stud which improves the coupling of the top plate to the Plinth and secures the motor corner.	Mar. 1992	88950
LP12 Mechanics Only LP12 sold as a mechanical assembly only. Three power supply options available: Lingo, Valhalla and Basik. Valhalla and Basik (Basik PSU supplied with 45 rpm adaptor).	1991	87600
Trampolin Kit. Suspended base board available as an upgrade	1991	N/A
Solid Base Board Replacing hardboard base	1991	87672
Motor Thrust Pad Small cap factory fitted (glued in position) to reduce noise level.	1991	87047 (Val) 87206 (Lingo)
Lingo Direct coupled power supply for the LP12. Offers low noise oscillators, precision filtering, separate drive for both phases and electrical isolation from mains supply.	1990	N/A
Grommets Composition changed to a new harder, denser rubber. Improves performance of suspension.	1989	81000
Motor Thrust Pad Replaced with stainless steel ball bearing. Reduces motor noise.	1989	79700

LP12 HISTORY AND UPGRADE PATH (page 2)

Upgrade	Year	Serial Number (approx.)
<p>Armboard Material changed to MDF core, laminated top and underside. Increases rigidity of armboard, creating improved platform for tonearm.</p>	1987	79160
<p>Bearing Housing Improved bearing liner material and thrust pad specification. Bearing liner machined to tighter tolerances, thus creating better speed stability. Changed to black oil.</p>	1987	70,000
<p>Suspension Springs Manufactured to tighter tolerance; ground top and bottom. (changed from zinc to black) Further tightening of manuf. tolerance. Tightened grinding tolerance.</p>	1981 1986 1988	70,000
<p>Sub-chassis Added strengthening bar, spot welded in place. Increases rigidity and strength. Attached strengthening bar with epoxy glue. Superior bond; increases rigidity.</p>	late '70s 1984	54,100
<p>Plinth Enlarged corner blocks. Strengthens and increases rigidity of plinth.</p>	1984	53,000
<p>Valhalla Power Supply Electronic speed control with a sophisticated crystal controlled power supply. Isolates the rotation of the turntable motor from variations in the electrical supply.</p>	1982	38,800
<p>Nirvana Kit Improved material specification of many integral mechanical components. Improved suspension and stability.</p>	1981	32,800

LP12 HISTORY AND UPGRADE PATH (page 3)

Upgrade	Year	Serial Number (approx.)
Lid and hinges Lid prop removed and hinges changed to spring loaded, self supporting.	1979	27,000
Top-plate Added two holes for 6 x 0.5 self tappers into wood block.	1978	23,000
Main Bearing Liner material changed.	1974	2,000
Sub-Chassis Strengthened by addition of strap, spot welded in place.	1974	2,000
Motor Control Motor control pcb changed from terminal strip to small circuit board.	1974	2,000
Mains Switch Changed from two buttons to single switch with mains neon.	1974	2,000

LP12 SPECIFICATIONS

For your information we have listed below some of the LP12 technical specifications.

The LP12 is a precision built transcription turntable, chassis mounted in a strong solid kiln dried timber low resonance base, equipped with a moulded, hinged dustcover.

Outer Platter

12" diameter (305 mm) non-magnetic zinc aluminium alloy diecast and accurately machined on all surfaces to within 0.001" (0.025 mm) with optimum peripheral mass distribution. Weight approximately 9 lbs (4.1 kg). The platter is supplied with a felt mat.

Bearing

Single point system running in an oil bath. The thrust pad, which must support the weight of the platter on a single point, is top grade steel, machined, hardened, ground and lapped to a mirror finish.

Motor

24-pole precision synchronous low noise, high torque motor. Fully shielded and mechanically isolated from the main bearing assembly by resilient mounting, damped three point suspension and a resilient belt drive.

Drive

Flat precision ground neoprene rubber belt driven by a concentric drive pulley. Concentricity 0.0004" (0.01 mm).

Suspension

the platter, bearing assembly and arm mounting board are mounted on a free floating inner chassis. This chassis is isolated from the plinth by a fully adjustable three point spring damped suspension.

Inner Chassis

The free floating inner, single piece pressed steel, (sub) chassis employs a strengthening strap, glued in place.

Top-plate

Heavy guage non-magnetic, brushed satin, stainless steel plate.

Power Supplies

Three supplies are available:

- a Basik, a single speed basic Mains power supply.
- b Valhalla on-board single speed (33.3 rpm) power supply.
- c Lingo, a direct coupled two speed (33.3 rpm and 45 rpm) outboard supply.

Basik power supply rely on the mains frequency therefore require either a 50 or 60 Hz motor fitting to the LP12 according to country of use. This supply is also voltage specific.

Both Valhalla and Lingo will operate from 100 V to 260 V, with a simple voltage adjustment -- ,

Valhalla: move one main input wire and the fuse inside the LP12.

Lingo: move the voltage barrel and change the fuse 200ma for @100V and 300ma for 200V+ on the Lingo.

Both Valhalla and Lingo generate 50Hz regardless of the mains frequency , so use a standard 50Hz motor.

Physical and Electrical Specifications

Power requirements: 110 - 125 Volts; 200- 260 Volts 50 Hz or 60 Hz

Dimensions:

Width	445 mm
Depth	356 mm
Height	140 mm

Approx. 70 mm required at rear, and approx. 250 mm above the unit to permit opening of lid.